

EXT-420 Butane/Propane Extraction Pumps

High-Pressure Positive-Displacement Piston Pumps

Models EXT-420 and EXT-420-2

EXT-420 high-pressure, positive-displacement two-stage piston pumps are safe, proven, reliable, and energy saving butane / propane extraction pumps. The high-pressure pumps offer the flexibility to speed completely variable from zero to maximum lbs/minute. No need for unloaders or bypass valves, simply add gauges and hoses to suit your application.

Applications

Designed for supercritical extraction of essential botanical oils



Features and Benefits

- Safe for handling propane and butane (Vent port must be connected to an exhaust line that vents leaked gas outdoors)
- Viton and PTFE seals
- Stainless steel and aluminum wetted components
- High butane transfer rates
- No electrical components
- Stall against load - start against load - or run dry
- Requires compressed air to drive the pump - approximately 30 CFM at 100 psi (7 bar) to run the pump at maximum speed (about 60 cycles per minute)
- Clean – No lubrication required in the gas section - Nothing is added to the gas

Operation

Proper operation of the Haskel EXT420 pumps will require the following additional equipment:

- Compressed air source capable of providing approximately 25 CFM of air at 90 psi (6.2 bar) or higher (Compressor must be located in an area away from the LPG gasses)
- Compressed air filter filtering to 40 microns or better
- Drive air pressure regulator
- Drive air speed control valve - such as a gate valve or a globe valve (not a ball valve)

Operation Schematic

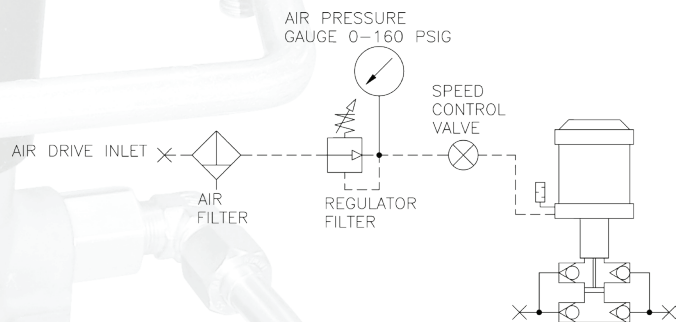

Model Number Configuration

EXT – Extraction Pump

4 – Pump has a ratio of 4:1

20 – Pump displacement of 20 cubic inches

EXT-420 Specifications

- Single stage
- Ideal when inlet pressures are 25 to 50 psi (1.7 to 3.4 bar) and outlet pressures are 125 to 150 psi (8.6 to 10.3 bar)
- Pump will transfer approximately 1/2 lb/min with an inlet pressure of 50 psi (3.4 bar) and an outlet pressure of 150 psi (10.3 bar) at maximum speed
- Will draw pressure down to 15 psi (1 bar) with an outlet pressure of 150 psi (10.3 bar)

EXT-420 Single Stage Flow Rate

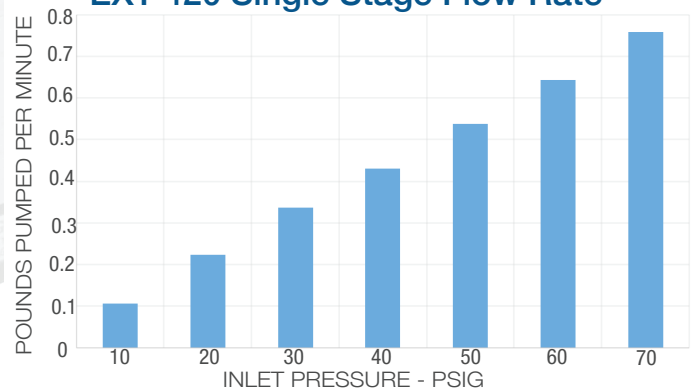

EXT-420 Dimensions

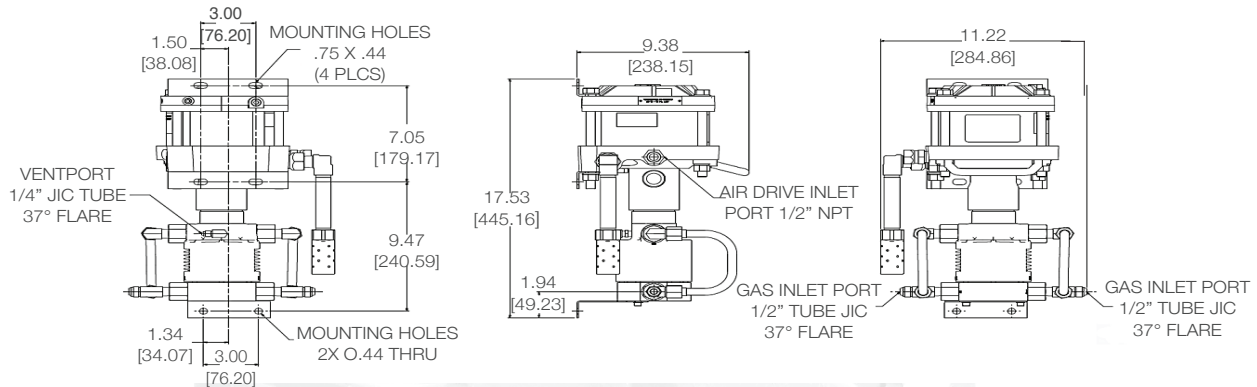

EXT-420-2 Specifications

- Switchable between single and two-stage mode by turning a valve
- Use single stage mode for most of the transfer - when the inlet pressure starts to drop - switch to two-stage mode to pull vacuum as your process requires
- In single stage mode - the pump has identical performance to EXT420
- Two stage mode allows the pump to draw vacuum down to 23-in. Hg

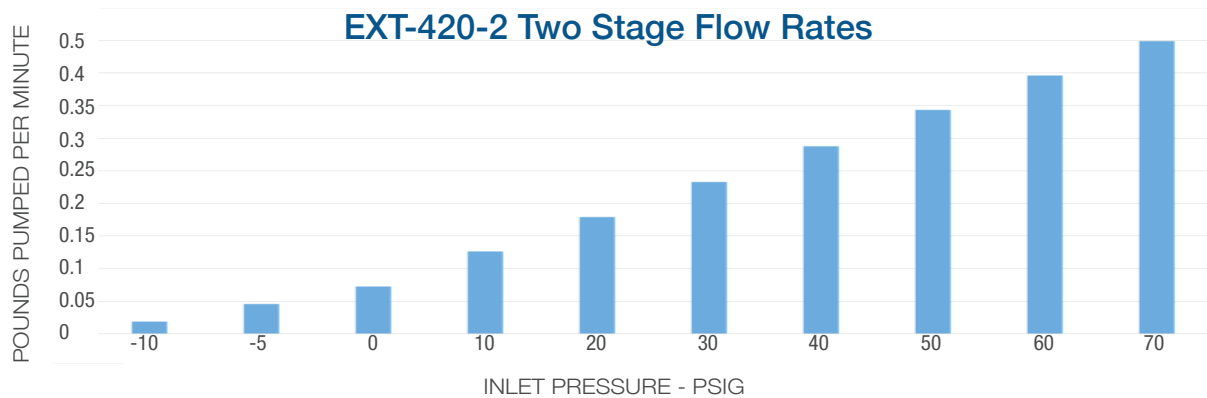

EXT-420-2 Dimensions

